

No.	DESCRIPTION	MATERIAL
1	SPUD	CAST LOW LEAD BRASS ALLOY
2	CONN. NUT	CAST BRASS ASTM B62 ALLOY C83600
3	CTS GSKT SUB	SBR ASTM D2000 - GSKT 410 <sub>SS</sub> - BAND

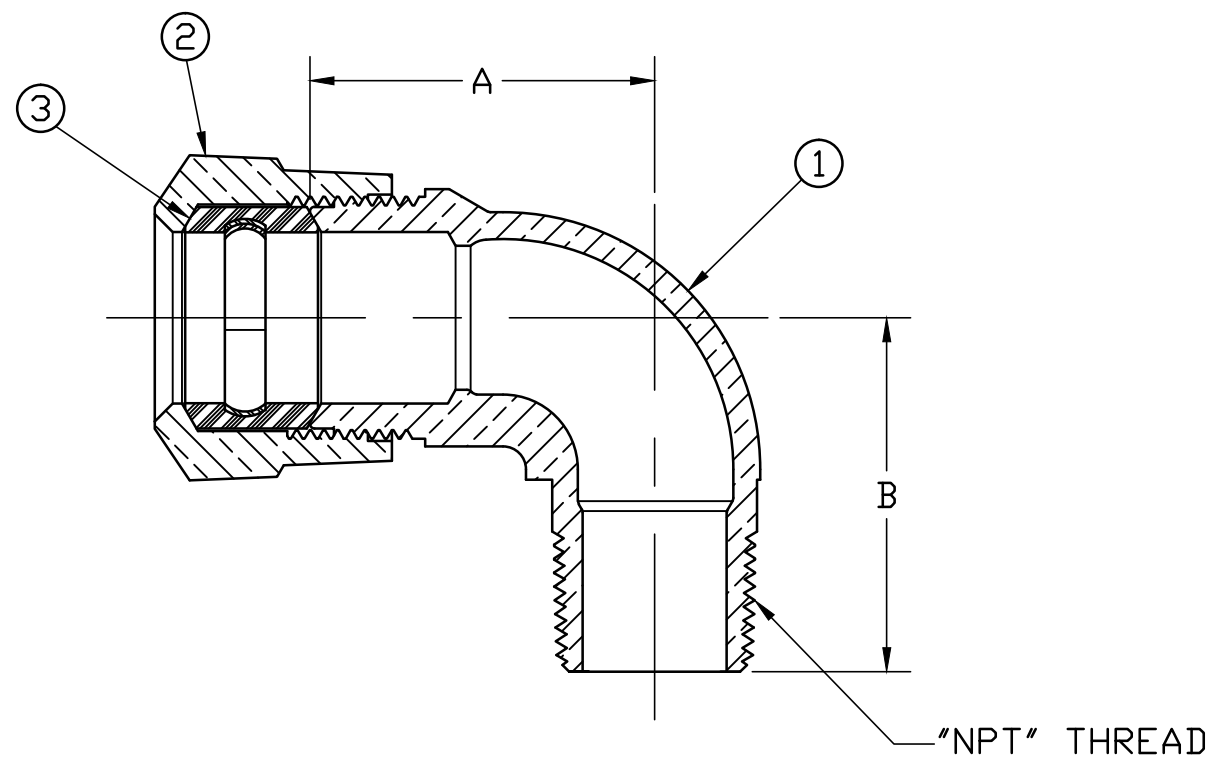

SIZE	A	B	NPT SIZE
3/4	1-51/64"	1-27/32"	3/4"
1	2"	2"	1"
1-1/2	2-3/4"	2-5/8"	1-1/2"
2	3-3/32"	2-31/32"	2"

ALL WETTED PARTS ARE LOW LEAD BRASS ALLOY

FILEPATH: PROD-ENG\JJ\SUBMITTALS\E2619SG

						DRFTR	RWB	7/27/09	<b>JONES</b>
						CHKR			
						ENGR			
						MGR			
							BY	DATE	UNLESS OTHERWISE NOTED SURFACE PREPARATION: BREAK CORNER(S) ---- .000 SURFACE FINISH -- XX RMS TOLERANCE(S): LINEAR ----- ± .000 ANGULAR ----- ± 0°00'
							STK No:		THIRD ANGLE PROJECTION 
							MAT'L:		REF. No.
							DESCR.		SCALE
							QUARTER BEND UNION SERVICE FITTING (MIP x 110 CTS) LOW LEAD BRASS		
									DWG NUMBER E2619SG
REV	ECR	DESCRIPTION	DATE	BY	CHKR				

TITLE TO AND OWNERSHIP OF THIS ENGINEERING DATA REMAINS IN Mueller Co. NO USE IS TO BE MADE OF THIS DATA EXCEPT AS SPECIFICALLY AUTHORIZED BY Mueller Co. ASSENT ON THE PART OF THE RECIPIENT TO THESE CONDITIONS IS PRESUMED.

DWG NUMBER  
E2619SG  
JJ-MRKTG