

No.	DESCRIPTION	MATERIAL
1	SPUD	CAST LOW LEAD BRASS ALLOY
2	WASHER	COPPER ASTM B152 ALLOY C11000
3	COPPER TUBE NUT	CAST BRASS ASTM B62 ALLOY C83600

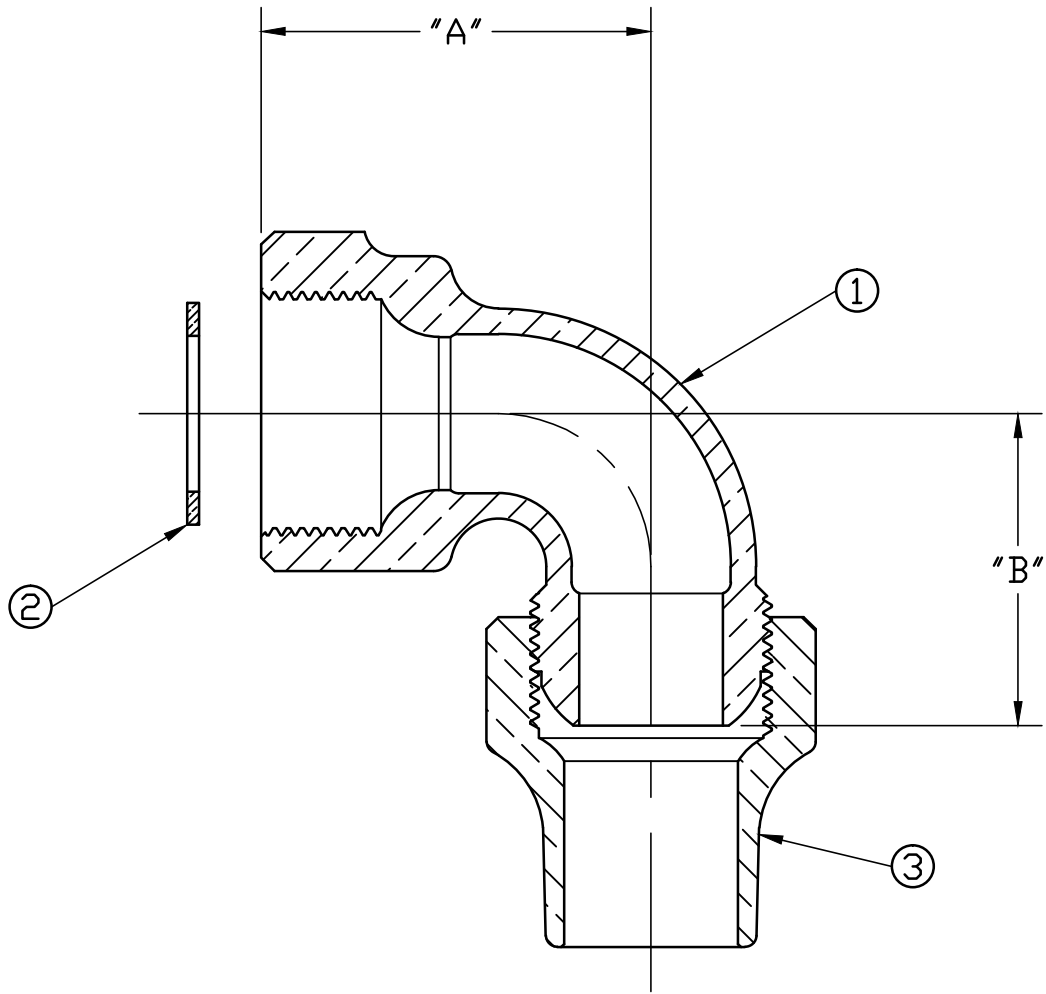

SIZE	A	B
3/4	2-1/32"	1-5/8"
1	2-5/16"	2-1/8"
1-1/2	3-1/16"	3-1/2"
2	3-15/16"	3-3/4"

ALL WETTED PARTS ARE LOW LEAD BRASS ALLOY

FILEPATH: PROD-ENG\JJ\SUBMITTALS\E1548

DWG NUMBER
E1548
JJ-MRKTG

TITLE TO AND OWNERSHIP OF THIS ENGINEERING DATA REMAINS IN Mueller Co. NO USE IS TO BE MADE OF THIS DATA EXCEPT AS SPECIFICALLY AUTHORIZED BY Mueller Co. ASSENT ON THE PART OF THE RECIPIENT TO THESE CONDITIONS IS PRESUMED.

DRFTR	JGarvin	9/25/09	JONES		
CHKR					
ENGR					
MGR					
UNLESS OTHERWISE NOTED			THIRD ANGLE PROJECTION		
SURFACE PREPARATION:					
BREAK CORNER(S) ---- .000					
SURFACE FINISH -- XX RMS			REF. No.		
TOLERANCE(S):			SCALE		
LINEAR ----- ± .000			FULL		
ANGULAR ----- ± 0°00'					
BY DATE					
STK No:					
MAT'L:					
DESCR.			DWG NUMBER		
LLB CORP STOP COUPLING QUARTER BEND			E1548		
("CS" COUPLING x CS)					
REV	ECR	DESCRIPTION	DATE	BY	CHKR